



Immigrants' Rights & Resource Guide

Last Updated: Dec. 19, 2024 9:30 pm

Note: This document is provided by the Department of Communications of the ACLU of Connecticut, and is intended for educational, civic, and advocacy purposes. This is not provided by our legal team, nor does anything in this document constitute legal advice. Please contact media@acluct.org with any questions.

Immigration Law in the US and Connecticut:

The United States federal government regulates immigration law nationwide. Congress controls immigration statutes, but the executive branch is charged with enforcement. SCOTUS has consistently upheld that immigration law belongs in federal jurisdiction via the Supremacy Clause.

States can have some laws governing how immigrants experience life in their state, but explicitly cannot regulate immigration via state law.

For example, some states (like Connecticut) limit the information-sharing and interactions that local and state law enforcement can have with immigration officials. Some states also provide certain benefits to immigrant residents. Connecticut law is clear: if ICE wishes to detain or deport someone, it can expend its own resources and time doing so. Local and state law enforcement are under no obligation to assist with this process. Local and state police do not need to arrest, transport, or detain people for ICE, nor do local jails, courthouses, or prisons need to allow ICE to roam their facilities.

Connecticut's most commonly referenced immigration statute is called [The Trust Act](#), which [prohibits state law enforcement](#) from doing ICE's job for them. Learn more about [how the U.S. immigration system works](#).

What do we expect on January 20th?

- **Attempt to eliminate birthright citizenship and denaturalize American citizens.**
- **Reinstitute Muslim ban:** A travel ban is likely to go into effect soon after inauguration. The ban is likely to include citizens of the countries targeted in the first Trump administration: Kyrgyzstan, Nigeria, Myanmar, Sudan, Tanzania, Iran, Libya, North Korea, Syria, Venezuela, Yemen, and Somalia. New countries could be added to this list, particularly China and India. International students and scholars from outside of these "areas of concern" are not likely to be affected by a travel ban or targeted visa suspension. People who are not citizens of these countries but are in transit through them to the U.S. are unlikely to be affected.
- **Further restrictions on asylum.**
- **Eliminate protections for Deferred Action for Childhood Arrivals (DACA) and Temporary Protected Status (TPS).**
- **Undermine protections for unaccompanied minors and families.** In Connecticut, residents can **go to probate court** to designate temporary guardians for children who will remain in Connecticut if their parent(s) or guardian(s) leaves the country, is deported, or taken to a mass detention site. Generally, temporary guardianship is good for one year but can be extended through subsequent visits to the probate court. There may be forms and actions that clerks at a probate court can help with that could be advantageous for someone's immigration status.
- **Mass deportations:** The president-elect has indicated mass deportations could begin soon after he takes office. These are likely to focus initially on people with final orders of deportation. Mass deportations are also likely to be challenged in the courts and to take longer than promised. Immigrants should make sure they have a safety plan, and copies of all documents they or their family might need. The most targeted individuals will be those living with a criminal record and those flagged for final deportation orders.



ACLU

Connecticut

What do we expect on January 20th? [cont.]

- **University students and employees should take [note](#):** It is a good idea for international students, faculty, and university staff from the above countries to be back in the U.S. in advance of the semester, which begins January 21, 2025. If this is not possible (e.g., for scheduled fieldwork), communicate with an advisor about your travel plans and be prepared for delays.
- **Longer visa processing times:** Applications for new employment-based visas or extensions (e.g., H-1B or O-1) may take longer. Start the process well ahead of deadlines. Employers may file for an extension of H-1B status six months in advance of the extension start date. Reduced staffing levels and increased background checks at U.S. consulates abroad may also lengthen visa processing times.

What can a private citizen do to help neighbors who we don't want to see deported?

KNOW YOUR RIGHTS and the rights of immigrant residents. Collective power, staying in community, and standing up for one another is much more effective than barring the door if ICE comes to a person's home. We recommend the following:

- Get to know law enforcement and municipal officials in your town. Talk with them intentionally about how policies that pit people against one another are bad for public safety. Use the word “residents” instead of “citizens,” and talk about how public safety should actually encompass all people, and not an idea of public safety that is rooted in bias and does not reflect the actual views of the community.
- Humanize yourself, your law enforcement officers, your elected officials, and your community members – but keep in mind that systems-level change can be necessary even if everyone involved is a “good person” who is “just doing their job.” Expansive views of public safety uphold the multicultural and pluralist values that the majority of Americans actually believe in, especially when they see themselves as living in a community.
- Contact your local elected officials and let them know you expect municipalities to create **Immigration Raid Task Forces** that will create protocols, policies, and services in the event of an immigration enforcement raid. The task force should include representatives from city agencies including education, health, and related welfare services who will assist impacted community members to find loved ones, secure legal assistance, and provide support for relatives, including U.S. citizen children left behind when a family member is arrested by immigration officials.

These interagency bodies can provide support by doing community outreach, liaising with immigration and other service providers, creating a hotline to report a raid, and assisting city staff—for example, at schools or hospitals—in responding when they witness an immigration enforcement action or get an inquiry from immigration agents about someone receiving their services. This coordination is essential to assist impacted community members get rapid legal assistance, to counter misinformation, and to build and maintain community trust. The ACLU has provided this guidance to state officials in Connecticut.

- Do this with local, state, and national officials.

Senator Blumenthal: Phone 860.258.6940 | [Email](#)
Senator Murphy: Phone 860.549.8463 | [Email](#)
Rep. Larson (CT-1): Phone 860.278.8888 | [Email](#)
Rep. Courtney (CT-2): Phone 860.886.0139 | [Email](#)
Rep. DeLauro (CT-3): Phone 203.562.3718 | [Email](#)
Rep. Himes (CT-4): Phone 860.453.0028 | [Email](#)
Rep. Hayes (CT-5): Phone 860.223.8412 | [Email](#)

Contact Governor Lamont: Phone 860.566.4840 | [Email](#)
Contact Lt. t. Governor Bysiewicz: Phone 860.524.7384 | [Email](#)
Contact Attorney General Tong: Phone 860.808.5318 | [Email](#)
[Contact State Senators](#)
[Contact State House Representatives](#)
Hartford Mayor's Office: Phone 860.757.9311 | [Email](#)
New Haven Mayor's Office: Phone 203.946.8200 | [Email](#)
Bridgeport Mayor's Office: Phone 203.576.7201 | [Email](#)
Stamford Mayor's Office: Phone 203.977.4150 | [Email](#)

What can a private citizen do to help neighbors who we don't want to see deported? [cont.]

- Contact your local elected officials and demand **immigration defends funds**, and an allocation of funding for immigration legal consultations and legal representation to include affirmative relief, which does not require people to have an immigration case in court, as well as in removal cases. In addition, allocate funding to cover application fees for those who could not otherwise afford them. (See The Vera Institute's [Fairness to Freedom Campaign](#))
- Promote the creation of **immigration legal clinics** in your town or city.
- Contact city and state officials and **ask about a Data Privacy Act**. Depending on how a city's charter distributes local government powers, either a mayoral executive order or city council legislation can be used to prohibit local government agencies (including law enforcement) from purchasing any data, or receiving any previously purchased data, for the purpose of engaging in any investigatory or criminal enforcement action. In cities that adopt a Fourth Amendment Is Not For Sale Act, such information could only be obtained by local law enforcement if (1) it secures a judicial warrant for the information or (2) if the information is provided voluntarily by someone who did not purchase it (allowing others to purchase information and provide it to law enforcement would make it easy to circumvent the rule).

Should I physically put my body between ICE and my immigrant neighbor, such as barring the door to obstruct their arrest?

The ACLU of Connecticut generally does not give advice about the consequences of intentionally breaking the law, whether for civil disobedience or any other purpose. The best thing you can do is Know Your Rights and know the rights of any undocumented person in your community. Bearing witness and being able to locate resources in case of arrests is powerful.

Which Connecticut residents are the most at risk for being deported or arrested by ICE?

Immigrants – regardless of how long they have been in the United States – could experience harm, whether in the form of fear mongering, discrimination, or a violation of their rights. People without secure immigration status, people who were ordered deported in the past and people who have had contact with the criminal legal system are at particular risk. More information is available at the [National Immigrant Justice Center](#).

Most of the immigrants taken into custody by U.S. Immigration and Customs Enforcement (ICE) are at border crossings, or are referred from state and local prisons and jails. State and local law enforcement in Connecticut are prohibited by law from alerting ICE if they detain or release an immigrant eligible for deportation.

Immigrant Deportations: Trends and Impacts ([Econofact](#), 2024 – Brookings Institution)

Will the ACLU help immigrants and families?

Yes. On the federal, state, and local level, the ACLU is working to protect your rights and litigate government overreach and unconstitutional actions. We have policy experts, lawyers, advocates, and community organizers working every day in the Capitol, statehouses, courthouses, and in your communities. We also work in coalitions with community partners in direct legal services and other direct services, and serve as a resource clearinghouse for that information.

Please feel free to get in contact with us at info@acluct.org.

What is a citizenship or immigration "status"?

There are more than 60 types of citizenship and immigration status. Some of these include:

US Citizen (via birthright, naturalization, derivation, or acquisition)	Conditional Permanent Resident
Permanent Resident (through family, business, lottery, or humanitarian bases)	Refugees and Asylees
Non-Immigrants (students, tourists, diplomats)	DACA/"Dreamers"
Undocumented Person	Temporary Protected Status (TPS)

I'm an immigrant. What can I do to prepare?

- **Seek legal consultation:**
 - American Immigration Lawyers Association: [1-800-954-0254](tel:1-800-954-0254)
 - National Immigration Legal Services Directory for Connecticut: <https://www.immigrationadvocates.org/legaldirectory/search?state=CT>
- **Create a safety plan:**
 - Identify your emergency contacts and memorize their phone numbers.
 - Provide your child's school or day care with an emergency contact to pick up your child.
 - Provide authorization in writing for your emergency contact to make medical and legal decisions for your child.
 - Tell your loved ones that if you are detained by ICE, they can try to use ICE's online detainee locator to find you: <https://locator.ice.gov/odls/#/search>.
 - Learn about guardianship, so that your children could be cared for by the person of your choosing rather than being sent into the foster system if you are detained. Probate court can help with this.
 - Consider putting a power-of-attorney document in place so that a person of your choosing may retain a lawyer and/or file suit on your behalf if you are detained by ICE and unable to communicate with the outside world.
- **Collect documents in a safe place:**
 - Keep your identity information and financial information in a safe location.
 - Gather documents showing the length of time you have been in the United States; the most recent two years are most important. This can include U.S. income tax returns, utility bills, leases, school records, medical records, bank records, or other documents.
 - Make sure your emergency contact can access all of these documents.
- **Know your rights and know what to do when encountering ICE:**
 - See the Know Your Rights section on the next page. Know Your Rights resources are on the following page.
- **Avoid immigration fraud:**
 - Only seek legal advice from an attorney or an accredited representative at a Department of Justice-recognized nonprofit organization.
 - Lawyers must have a license from a U.S. state to practice law. Ask to see their law license. Law licenses from other countries do not authorize the practice of law in the United States.
 - Accredited representatives must be accredited and work for a nonprofit agency recognized by the Department of Justice. Ask to see their accreditation documents.
 - Never sign an application with false information.
 - Never sign a blank form.
 - Ask for copies of everything you sign.
 - If the advice sounds too good to be true, get a second opinion before filing an immigration application.
 - Read NIJC's [full guidance on how to avoid immigration fraud](#).
- **Be alert for digital scams:**
 - Be skeptical of social media posts promising new or quick immigration relief.
 - The U.S. government (including Department of Homeland Security, U.S. Citizenship and Immigration Services, Immigration and Customs Enforcement, and State Department) will never contact you via WhatsApp or social media.
 - With limited exceptions, such as people who are released from detention and told they must check in with ICE via telephone, the U.S. government generally does not contact individuals by phone.
 - If you receive an unexpected message or phone call from someone who claims they are an immigration officer or other government official, do not respond or share personal information. Do not wire or transfer money to pay a "processing fee" or for any other reason.
 - If in doubt, consult an attorney or accredited representative before taking any action.
 - Avoid sharing unverified information on social media.



ACLU

Connecticut

Know Your Rights

What happens if I get stopped on the street by ICE?

- Do not run. Remain calm.
- If officials ask for your name, you must tell them. You do not have to answer any other questions.
- You can ask if you are free to go. If the answer is yes, you may walk away calmly.
- It is best not to lie or carry false documents with you.

What are my rights if I am arrested?

- If they ask for your name, you must tell them. You don't have to answer other questions.
- You have the right to remain silent. If you wish to exercise that right, say so out loud and ask for a lawyer right away.
- You can ask to make a phone call and speak with your lawyer. Memorize the phone number of your lawyer or a family member or a trusted friend who is in the United States legally.
- You do not have to give information or answer any questions about your immigration status.
- You do not have to sign any documents.

Remember: it is best not to lie or carry false documents with you.

What can I do if ICE comes to my workplace?

- Do not run. If they are not looking for you, running will make you a target.
- If they ask for your name, you must tell them, but don't have to answer other questions.
- You can ask if you are free to go. If the answer is yes, you may walk away calmly.

Note: immigration does not need a warrant or permission to enter the public spaces of a business such as the dining room in a restaurant. They do need a warrant or permission to enter areas that are not open to the public, such as the kitchen in a restaurant.

You can carry this language below on a card with you and hand it to the police or immigration. Or slip it under your door, if immigration comes to your house:

- I am exercising my constitutional rights. I do not wish to speak with you. I will not open the door unless you have a warrant signed by a judge.
- Estoy ejerciendo mis derechos constitucionales. No deseo hablar contigo. No voy a abrir la puerta a menos que tenga una orden judicial firmada por un juez.

Note: printable cards in English and Spanish can be found at the end of this resource guide.

What can I do if ICE comes to my home?

- You do not have to open the door.
- You can ask the officials if they have a warrant. You can ask the officials to pass the warrant under the door.
- You can confirm that the warrant has been signed by a judge or magistrate. Only a warrant signed by a judge or magistrate allows immigration officials to enter your home to search your home or make an arrest.
- Remember that a warrant of removal/deportation (Form I-205) does not allow officers to enter a home without consent.
- An arrest warrant will name the person they are looking for. If they only have an arrest warrant, you do not have to agree to let them search your home.
- If the warrant is not signed by a judge or magistrate, you do not have to open the door or allow entry to your home.
- If they enter your home anyway, you have the right to ask for the names and badge numbers of the officer and say you did not agree to the search.
- Even if the warrant is valid and immigration officials are allowed to enter your home or make an arrest, you do not need to answer their questions. You have the right to remain silent, even if the officer has a warrant.
- If you are arrested, you can ask to speak with an attorney.

Note: if immigration officials take items from your home, keep a record of what they took and ask for a receipt for the items.



ACLU

Connecticut

Know Your Rights Resources

Immigrant Legal Resource Center

- **SHOW THIS CARD** through the door or window if ICE is at your home:
https://www.ilrc.org/sites/default/files/documents/red_card-self_srv-english.pdf
- **Printable in 15 languages:**
<https://www.ilrc.org/red-cards>
- **Immigration Preparedness Toolkit:**
https://www.ilrc.org/sites/default/files/resources/imm_preparedness_kit_april2020_1.pdf
- **Family Preparedness Plan:**
<https://www.ilrc.org/resources/step-step-family-preparedness-plan>

Note: printable cut-outs of the Red Card can be found at the end of this resource guide.

National Immigrant Justice Center

- **ICE in Your Community:**
<https://immigrantjustice.org/know-your-rights/ice-encounter>

Mobilization for Justice

- **Interacting with ICE in Public Spaces:**
<https://mobilizationforjustice.org/wp-content/uploads/Interacting-with-ICE-in-Public-Spaces.pdf>
- **Interacting with ICE at Home:**
<https://mobilizationforjustice.org/wp-content/uploads/Interacting-with-ICE-at-home.pdf>
- **Interacting with ICE in the Courts:**
<https://mobilizationforjustice.org/wp-content/uploads/Interacting-with-ICE-in-Courts.pdf>

ACLU Resources

- **Law Enforcement Asks About Immigration Status:**
<https://www.aclu.org/know-your-rights/immigrants-rights#law-enforcement-asks-about-my-immigration-status>
- **Stopped by Police or ICE:**
<https://www.aclu.org/know-your-rights/immigrants-rights#ive-been-stopped-by-police-or-ice>
- **Police or ICE are at My Home:**
<https://www.aclu.org/know-your-rights/immigrants-rights#police-or-ice-are-at-my-home>
- **I Need A Lawyer:** <https://www.aclu.org/know-your-rights/immigrants-rights#i-need-a-lawyer>
- **I've Been Detained Near the Border at Border Patrol:** <https://www.aclu.org/know-your-rights/immigrants-rights#ive-been-detained-near-the-border-by-border-patrol>
- **I Was Stopped by Police, ICE, or Border Patrol While in Transit:** <https://www.aclu.org/know-your-rights/immigrants-rights#i-was-stopped-by-police-ice-or-border-patrol-while-in-transit>
- **Detained While My Immigration Case is Underway:** <https://www.aclu.org/know-your-rights/immigrants-rights#i-am-detained-while-my-immigration-case-is-underway>
- **I've Been Arrested & Need to Challenge A Deportation Order:** <https://www.aclu.org/know-your-rights/immigrants-rights#ive-been-arrested-and-need-to-challenge-a-deportation-order>
- **Encountering Questions from Law Enforcement:**
<https://www.aclu.org/know-your-rights/what-do-when-encountering-law-enforcement-questioning>



ACLU

Connecticut

Legal Help for Immigrants

2-1-1 of Connecticut has more resources for immigrants [here](#).

This page will be updated as more resources become available.

- **Greater Hartford Legal Aid**
 - <https://www.ghla.org/>
 - (860) 541-5000
- **Connecticut Legal Services**
 - <https://ctlegal.org/>
 - (860) 225-8678
- **New Haven Legal Assistance**
 - <https://nhlegal.org/>
 - (203) 946-4811
- **Connecticut Institute for Refugees and Immigrants**
 - <https://cirict.org/>
 - Bridgeport: (203) 336-0414
 - Stamford: (203) 965-7190
 - Hartford: (860) 692-3085
- **Apostle Immigrant Services**
 - <https://www.apostleimmigrantservices.org/>
 - (203) 752-9068
- **IRIS - Integrated Refugee and Immigrant Services**
 - <https://irisct.org/>
 - (203) 562-2095
- **Building One Community**
 - <https://building1community.org/>
 - (203) 674-8585
- **The Jerome N. Frank Legal Services Organization of Yale Law School**
 - <https://law.yale.edu/studying-law-yale/clinical-and-experiential-learning/jerome-n-frank-legal-services-organization-lso>
 - (203) 432-4800
- **University of Connecticut School of Law, Asylum and Human Rights Clinic**
 - <https://www.law.uconn.edu/academics/clinics-experiential-learning/asylum-human-rights-clinic>
 - (860) 570-5165
- **Immigration Advocates Network**
 - <http://www.immigrationadvocates.org/nonprofit/legaldirectory>
- **American Immigration Lawyers Association**
 - <https://www.aila.org/>
 - 1 (800) 954-0254

Red Card Cut-Outs (ENGLISH)

To print at home, use heavy weight paper, or card stock. Cut out the cards along the dotted lines. If you're unable to print on both sides, you can simply fold on the center line to make a 2-sided card.

If you use a professional printer, we suggest you print 2-sided cards with white text on red card stock with rounded corners.

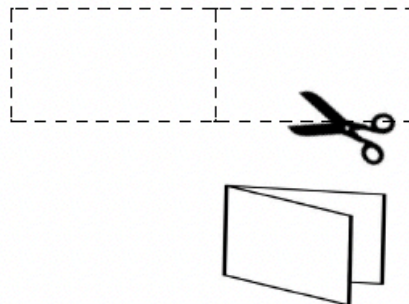

You have constitutional rights:

- **DO NOT OPEN THE DOOR** if an immigration agent is knocking on the door.
- **DO NOT ANSWER ANY QUESTIONS** from an immigration agent if they try to talk to you. You have the right to remain silent.
- **DO NOT SIGN ANYTHING** without first speaking to a lawyer. You have the right to speak with a lawyer.
- If you are outside of your home, ask the agent if you are free to leave and if they say yes, leave calmly.
- **GIVE THIS CARD TO THE AGENT.** If you are inside of your home, show the card through the window or slide it under the door.

I do not wish to speak with you, answer your questions, or sign or hand you any documents based on my 5th Amendment rights under the United States Constitution.

I do not give you permission to enter my home based on my 4th Amendment rights under the United States Constitution unless you have a warrant to enter, signed by a judge or magistrate with my name on it that you slide under the door.

I do not give you permission to search any of my belongings based on my 4th Amendment rights.

I choose to exercise my constitutional rights.

These cards are available to citizens and noncitizens alike.

You have constitutional rights:

- **DO NOT OPEN THE DOOR** if an immigration agent is knocking on the door.
- **DO NOT ANSWER ANY QUESTIONS** from an immigration agent if they try to talk to you. You have the right to remain silent.
- **DO NOT SIGN ANYTHING** without first speaking to a lawyer. You have the right to speak with a lawyer.
- If you are outside of your home, ask the agent if you are free to leave and if they say yes, leave calmly.
- **GIVE THIS CARD TO THE AGENT.** If you are inside of your home, show the card through the window or slide it under the door.

I do not wish to speak with you, answer your questions, or sign or hand you any documents based on my 5th Amendment rights under the United States Constitution.

I do not give you permission to enter my home based on my 4th Amendment rights under the United States Constitution unless you have a warrant to enter, signed by a judge or magistrate with my name on it that you slide under the door.

I do not give you permission to search any of my belongings based on my 4th Amendment rights.

I choose to exercise my constitutional rights.

These cards are available to citizens and noncitizens alike.

You have constitutional rights:

- **DO NOT OPEN THE DOOR** if an immigration agent is knocking on the door.
- **DO NOT ANSWER ANY QUESTIONS** from an immigration agent if they try to talk to you. You have the right to remain silent.
- **DO NOT SIGN ANYTHING** without first speaking to a lawyer. You have the right to speak with a lawyer.
- If you are outside of your home, ask the agent if you are free to leave and if they say yes, leave calmly.
- **GIVE THIS CARD TO THE AGENT.** If you are inside of your home, show the card through the window or slide it under the door.

I do not wish to speak with you, answer your questions, or sign or hand you any documents based on my 5th Amendment rights under the United States Constitution.

I do not give you permission to enter my home based on my 4th Amendment rights under the United States Constitution unless you have a warrant to enter, signed by a judge or magistrate with my name on it that you slide under the door.

I do not give you permission to search any of my belongings based on my 4th Amendment rights.

I choose to exercise my constitutional rights.

These cards are available to citizens and noncitizens alike.

You have constitutional rights:

- **DO NOT OPEN THE DOOR** if an immigration agent is knocking on the door.
- **DO NOT ANSWER ANY QUESTIONS** from an immigration agent if they try to talk to you. You have the right to remain silent.
- **DO NOT SIGN ANYTHING** without first speaking to a lawyer. You have the right to speak with a lawyer.
- If you are outside of your home, ask the agent if you are free to leave and if they say yes, leave calmly.
- **GIVE THIS CARD TO THE AGENT.** If you are inside of your home, show the card through the window or slide it under the door.

I do not wish to speak with you, answer your questions, or sign or hand you any documents based on my 5th Amendment rights under the United States Constitution.

I do not give you permission to enter my home based on my 4th Amendment rights under the United States Constitution unless you have a warrant to enter, signed by a judge or magistrate with my name on it that you slide under the door.

I do not give you permission to search any of my belongings based on my 4th Amendment rights.

I choose to exercise my constitutional rights.

These cards are available to citizens and noncitizens alike.

Red Card Cut-Outs (SPANISH)

Para imprimir en casa, utilice papel grueso o cartulina. Recorta las tarjetas por las líneas de puntos. Si no puede imprimir en ambas caras, simplemente puede doblar por la línea central para hacer una tarjeta de dos caras.

Si utiliza una impresora profesional, le sugerimos que imprima tarjetas de 2 caras con texto blanco en cartulina roja con esquinas redondeadas.

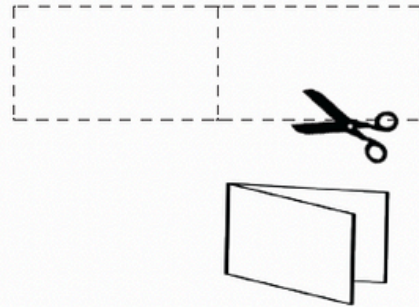

Usted tiene derechos constitucionales:

- **NO ABRA LA PUERTA** si un agente de inmigración está tocando la puerta.
- **NO CONTESTE NINGUNA PREGUNTA** de un agente de inmigración si el trata de hablar con usted. Usted tiene el derecho de mantenerse callado.
- **NO FIRME NADA** sin antes hablar con un abogado. Usted tiene el derecho de hablar con un abogado.
- Si usted está afuera de su casa, pregunte al agente si es libre para irse y si dice que sí, váyase con tranquilidad.
- **ENTREGUE ESTA TARJETA AL AGENTE.** Si usted está dentro de su casa, muestre la tarjeta por la ventana o pásela debajo de la puerta.

Usted tiene derechos constitucionales:

- **NO ABRA LA PUERTA** si un agente de inmigración está tocando la puerta.
- **NO CONTESTE NINGUNA PREGUNTA** de un agente de inmigración si el trata de hablar con usted. Usted tiene el derecho de mantenerse callado.
- **NO FIRME NADA** sin antes hablar con un abogado. Usted tiene el derecho de hablar con un abogado.
- Si usted está afuera de su casa, pregunte al agente si es libre para irse y si dice que sí, váyase con tranquilidad.
- **ENTREGUE ESTA TARJETA AL AGENTE.** Si usted está dentro de su casa, muestre la tarjeta por la ventana o pásela debajo de la puerta.

Usted tiene derechos constitucionales:

- **NO ABRA LA PUERTA** si un agente de inmigración está tocando la puerta.
- **NO CONTESTE NINGUNA PREGUNTA** de un agente de inmigración si el trata de hablar con usted. Usted tiene el derecho de mantenerse callado.
- **NO FIRME NADA** sin antes hablar con un abogado. Usted tiene el derecho de hablar con un abogado.
- Si usted está afuera de su casa, pregunte al agente si es libre para irse y si dice que sí, váyase con tranquilidad.
- **ENTREGUE ESTA TARJETA AL AGENTE.** Si usted está dentro de su casa, muestre la tarjeta por la ventana o pásela debajo de la puerta.

Usted tiene derechos constitucionales:

- **NO ABRA LA PUERTA** si un agente de inmigración está tocando la puerta.
- **NO CONTESTE NINGUNA PREGUNTA** de un agente de inmigración si el trata de hablar con usted. Usted tiene el derecho de mantenerse callado.
- **NO FIRME NADA** sin antes hablar con un abogado. Usted tiene el derecho de hablar con un abogado.
- Si usted está afuera de su casa, pregunte al agente si es libre para irse y si dice que sí, váyase con tranquilidad.
- **ENTREGUE ESTA TARJETA AL AGENTE.** Si usted está dentro de su casa, muestre la tarjeta por la ventana o pásela debajo de la puerta.

I do not wish to speak with you, answer your questions, or sign or hand you any documents based on my 5th Amendment rights under the United States Constitution.

I do not give you permission to enter my home based on my 4th Amendment rights under the United States Constitution unless you have a warrant to enter, signed by a judge or magistrate with my name on it that you slide under the door.

I do not give you permission to search any of my belongings based on my 4th Amendment rights.

I choose to exercise my constitutional rights.

These cards are available to citizens and noncitizens alike.

I do not wish to speak with you, answer your questions, or sign or hand you any documents based on my 5th Amendment rights under the United States Constitution.

I do not give you permission to enter my home based on my 4th Amendment rights under the United States Constitution unless you have a warrant to enter, signed by a judge or magistrate with my name on it that you slide under the door.

I do not give you permission to search any of my belongings based on my 4th Amendment rights.

I choose to exercise my constitutional rights.

These cards are available to citizens and noncitizens alike.

I do not wish to speak with you, answer your questions, or sign or hand you any documents based on my 5th Amendment rights under the United States Constitution.

I do not give you permission to enter my home based on my 4th Amendment rights under the United States Constitution unless you have a warrant to enter, signed by a judge or magistrate with my name on it that you slide under the door.

I do not give you permission to search any of my belongings based on my 4th Amendment rights.

I choose to exercise my constitutional rights.

These cards are available to citizens and noncitizens alike.

I do not wish to speak with you, answer your questions, or sign or hand you any documents based on my 5th Amendment rights under the United States Constitution.

I do not give you permission to enter my home based on my 4th Amendment rights under the United States Constitution unless you have a warrant to enter, signed by a judge or magistrate with my name on it that you slide under the door.

I do not give you permission to search any of my belongings based on my 4th Amendment rights.

I choose to exercise my constitutional rights.

These cards are available to citizens and noncitizens alike.